

EPIC-60C4

60-Slot PCIe/NVMe SSD Tester

- **Hardware designed and manufactured by Daichu Technologies**
 - **Sixty PCIe 3.0 x8 lane**
 - **Temperature range: -40 degC to +90 degC**
 - **Full Bandwidth Testing**
- **Software provided by OakGate Technology**
 - **Proven test software, used by most major SSD suppliers worldwide**



Key Features

- Thermal chamber with industry leading -40 degC to +90 degC temperature range
- Supports up to sixty edge card type SSDs
 - SFF(Single Port / Dual Port) & M.2 supported with attachments
- Comprehensive Functionality
 - Long-run testing
 - Aging test
 - Low and high temperature testing
 - Marginal voltage testing
- High-performance R/W access on thermal and marginal voltage test
- Discharge circuit can shorten voltage turn-off time and stabilize power cycle test
- No PCIe bridge chip used, resulting in stable software performance
- Test engine mounted outside, not affected by chamber temperature
- High-speed transmission route from PC to the device, provides a stable, high-speed serial communication
- Adjustable airflow ranging from 700 to 1500 LFM to each SSD
 - Various air speeds can be adjusted to accommodate end-user's requirements
- Preinstalled OakGate software with a user friendly GUI that allows the user to
 - Generate traffic and inject errors
 - Measure performance (IOPS, Bandwidth, Latency)
 - Control power and temperature
 - Execute customized test sequences, record logs
 - Test devices at full-performance
 - Exercise built-in protocol conformance test suite and analyzer

Specifications

Category	Item	Contents
Supported SSD Specs	Form Factor	AIC (HHHL)
	IF spec	PCIe 3.0 x8 lane
	Number of slots	60 slots
	Device supply power	50W / slot (total 3,000W)
Chamber Specs	Set Temperature	-40 to +90 degC (30w/slot) -30 to+90 degC (50w/slot)
	Airflow (Blow speed)	Approx. 700 ~ 1500 LFM (Adjustable)
	Door Lock	Locked less than 20 degC / more than 45 degC
SSD Power Supply	3.3V	2.5A (Typ.) 3.0A (Peak)
	12V	4.0A (Typ.) 5.0A (Peak)
	Voltage Margin	± 15%
	Voltage Slope	1 to 120msec : Setting adjustable for either 3.3V/12V
	Discharge Time	Free or less than 100msec (SSD Capacity < 500uF)
Test Engine	Software	Supported by OakGate (SVF)
	Motherboard	Dual CPU ATX (XEON E5)
	PCIe Slots	GEN3.0 x8 lane 10 slots
Other functions	LED Indicator	Power status (Power, SSD insertion) Test status (Idle, Run, Pass, Fail)
	Host PC IF	Ethernet (RJ45)
Option	SFF / M.2	SFF(8639) : Single Port attachment Dual Port attachment M.2 : M.2 attachment
Input Requirements	AC voltage(Hz) / Current	AC 208V (50/60Hz) / Max 75A
	Dry Air	6 m3/hrs. [0.5 to 1.0 MPa]
Mechanical	Dimensions	Approx. 1,300mm (W) x 1,450mm (D) x 2,050mm (H)
	Weight	Approx. 1,100kg

※Environmental Temperature : 22 to 28 degC

Block Diagram

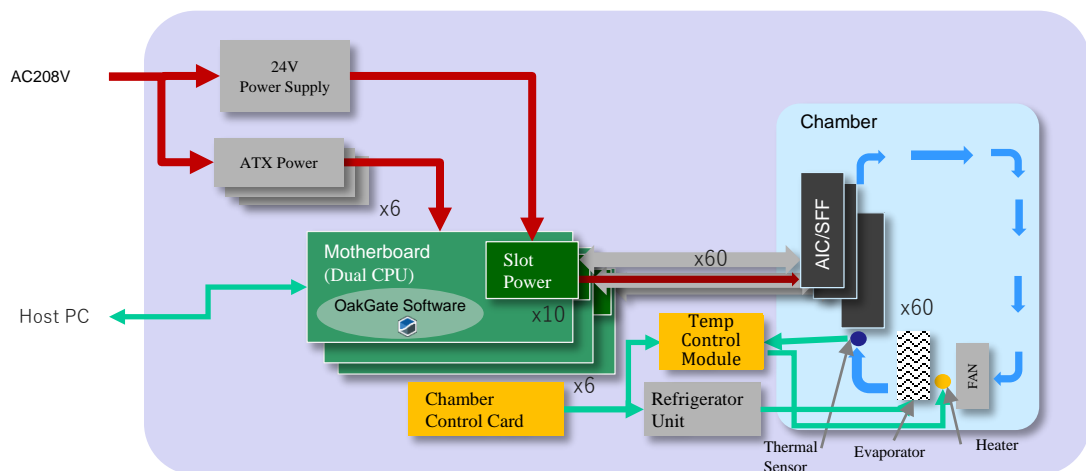

The information provided in this document is subject to change without prior notice.

 **Daichu Technologies Co.,Ltd.**

704-4 Miroku, Hanyu,
Saitama 348-8555, Japan
Tel +81-48-565-2822
Fax +81-48-565-2833
URL: <http://www.daichutec.co.jp/>

 **OakGate
TECHNOLOGY**

3256 Penryn Road, Suite 220
Loomis, CA 95659, USA
Tel +1 916.652.5132
URL: <http://www.oakgatetech.com>